

SunPower® X20-250-BLK-B-AC | Residential AC Module Series

Design-Driven Advantages

- #1 module aesthetics and efficiency
- Unmatched module reliability
- No electrolytic capacitor
- 25-year combined warranty

Maximum Value for Roof

- Size system for roof, not string inverter
- Optimize performance of each module

Reach New Customers

- Complex roofs
- Partial shading
- Small systems
- System expandability

Simple & Fast Installation

- Factory-integrated microinverter
- Robust, double-locking AC connectors
- AC architecture allows onsite design flexibility
- No DC string sizing process
- Fewer steps than competing AC systems or other MLPE
- Simple commissioning

Core of Superior System

- Built for use with SunPower InvisiMount™
- Best-in-class system reliability and aesthetics
- AC system means fewer parts, simpler design
- Pair with SunPower monitoring app for system data



Optimize System and Installation Efficiency

Factory-integrated SunPower® AC Modules provide a revolutionary combination of high efficiency, high reliability, and module-level DC-to-AC power conversion. Designed specifically for use with SunPower InvisiMount™ residential mounting system, SunPower AC Modules also achieve rapid installation and best-in-class system aesthetics. All this comes with an industry-leading 25-year AC module warranty. Finally, homeowners with complex or shaded roofs have an economically viable solar option.

sunpower.com



SUNPOWER®

SunPower® X20-250-BLK-B-AC | Residential AC Module Series

Model: X20-250-BLK-B-AC

DC Electrical Data			
Measured at Standard Test Conditions (STC): irradiance of 1000 W/m ² , AM 1.5, and cell temperature 25° C			
Nominal Power	P _{nom}	250 W	
Power Tolerance		+5/-0%	
Avg. Panel Efficiency	η	20.3%	
Rated Voltage	V _{mpp}	42.8 V	
Rated Current	I _{mpp}	5.84 A	
Open-circuit Voltage	V _{oc}	50.9 V	
Short-circuit Current	I _{sc}	6.20 A	
Temperature Coefficients	(Power)	P	-0.30 %/K
	(Voltage)	V _{oc}	-125.6 mV/K
	(Current)	I _{sc}	3.5 mA/K
Shade Tolerance	<ul style="list-style-type: none"> • Three bypass diodes • Integrated panel-level MPPT 		

Mechanical Data	
Solar Cells	72 Monocrystalline Maxeon™ Gen III
Front Glass	High-transmission tempered glass with anti-reflective (AR) coating
Environmental Rating	IP65
Frame	Class 1 black anodized (highest AAMA rating)
Weight	38.7 lbs (17.6 kg)
Max. Recommended Module Spacing	1.3 in (33 mm)

AC Electrical Data	
Output @ 240 V (min./nom./max.)	211/240/264 V
Output @ 208 V (min./nom./max.)	183/208/229 V
Operating Frequency (min./nom./max.)	59.3/60.0/60.5 Hz
Output Power Factor (min.)	0.99
AC Max. Cont. Output Current @ 240 V	0.99 A
AC Max. Cont. Output Current @ 208 V	1.14 A
AC Max. Cont. Output Power	238 W
DC/AC CEC Conversion Efficiency	95.0%
Max. Units Per Branch Circuit @ 240 V	16 (single phase)
Max. Units Per Branch Circuit @ 208 V	24 (three pole) or 14 (two pole)

Tested Operating Conditions	
Temperature	-40° C to +85° C (-40° F to +185° F)
Max. Load	Wind: 2400 Pa (50 psf, 245 kg/m ²) front & back Snow: 5400 Pa (112 psf, 550 kg/m ²) front
Impact Resistance	1 inch (25 mm) diameter hail at 52 mph (23 m/s)

Warranties and Certifications	
Warranties	<ul style="list-style-type: none"> • 25-year limited power warranty • 25-year limited product warranty
Certifications	<ul style="list-style-type: none"> • UL 1741, including compliance with applicable requirements of IEEE 1547 and IEEE 1547.1 • Type 2 Fire Rated • Alternating Current (AC) Module designation enables installation in accordance with NEC 690.6

Dimensions

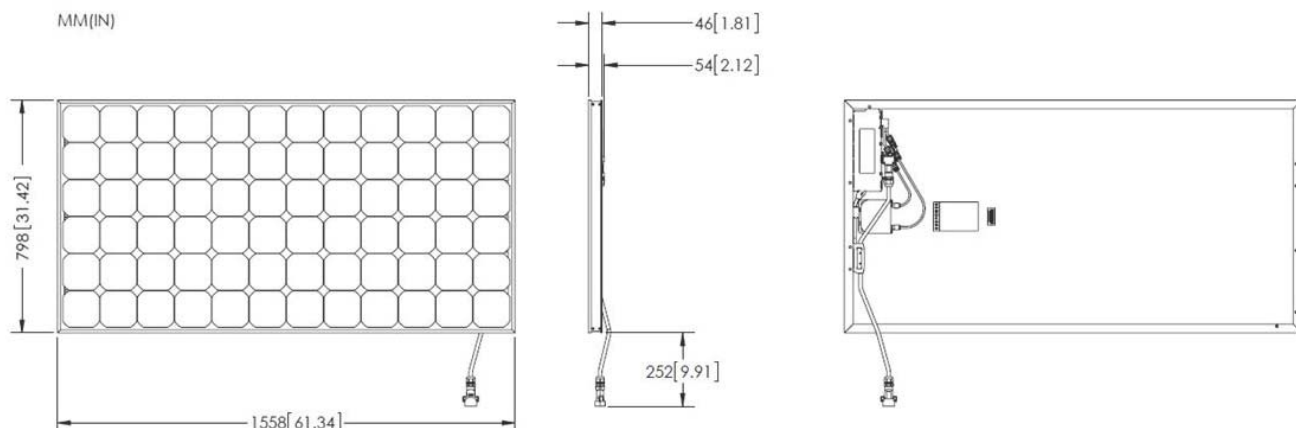

See <http://www.sunpower.com/facts> for more reference information.
For more details, see extended datasheet: www.sunpower.com/datasheets. Read safety and installation instructions before using this product.
©2015 SunPower Corporation. All rights reserved. SUNPOWER, the SUNPOWER logo, MAXEON, and SIGNATURE are trademarks or registered trademarks of SunPower Corporation. Specifications included in this datasheet are subject to change without notice.